



Free Grammar Checker

Eliminate grammar errors instantly and enhance your writing with Grammarly

Grammarly DOWNLOAD

International Journal of Hydrogen Energy

187

H Index

Country	United Kingdom - SIR Ranking of United Kingdom
Subject Area and Category	Energy Energy Engineering and Power Technology Fuel Technology Renewable Energy, Sustainability and the Environment Physics and Astronomy Condensed Matter Physics
Publisher	Elsevier Ltd.
Publication type	Journals
ISSN	03603199
Coverage	1976-ongoing
Scope	The International Journal of Hydrogen Energy provides scientists and engineers throughout the world with a central vehicle for the exchange and dissemination of basic ideas in the field of hydrogen energy. The emphasis is placed on original research, both analytical and experimental, which is of permanent interest to engineers and scientists, covering all aspects of hydrogen energy, including production, storage, transmission, utilization, as well as the economical, environmental and international aspects. When outstanding new advances are made, or when new areas have been developed to a definitive stage, special review articles will be considered. To encourage the exchange of ideas, a section of the journal is devoted to discussing previously published papers.

[Homepage](#)

[Join the conversation about this journal](#)

Free Grammar Checker

Eliminate grammar errors instantly and enhance your writing with Grammarly

Grammarly

DOWNLOAD

Quartiles

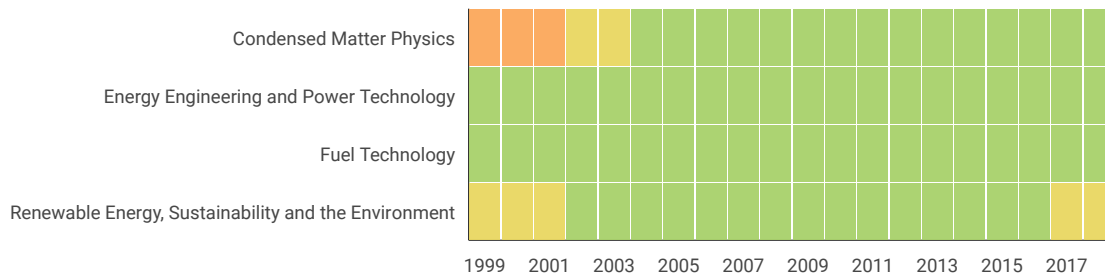

SJR

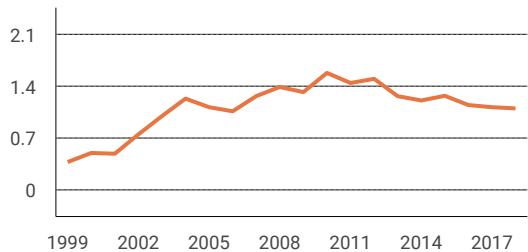

Citations per document

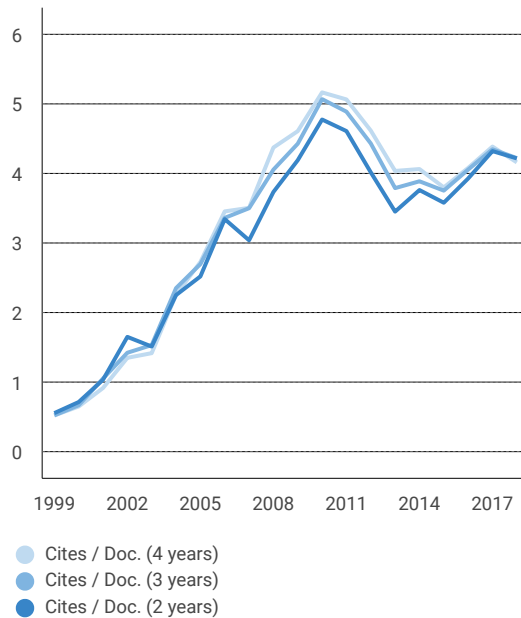

Total Cites Self-Cites

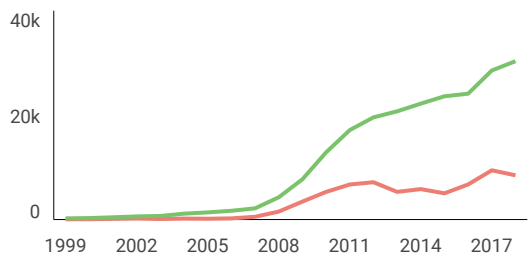

External Cites per Doc Cites per Doc

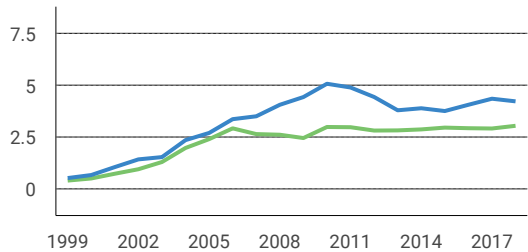

% International Collaboration

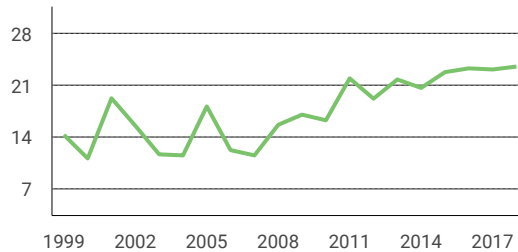

Citable documents Non-citable documents



Cited documents Uncited documents



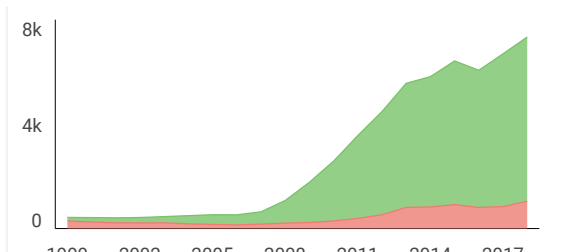
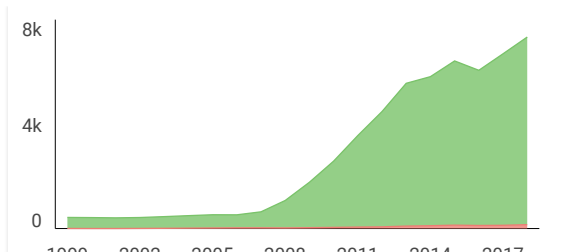

International Journal of Hydrogen Energy

Q1 Condensed Matter Physics
best quartile

SJR 2018
1.1

powered by scimagojr.com

← Show this widget in your own website

Just copy the code below and paste within your html code:

```
<a href="https://www.scimagojr.com" style="border: 1px solid #ccc; padding: 2px 5px; display: inline-block;">https://www.scimagojr.com
```

Leave a comment

Name

Email

(will not be published)

I'm not a robot

reCAPTCHA
[Privacy](#) - [Terms](#)

Submit

The users of Scimago Journal & Country Rank have the possibility to dialogue through comments linked to a specific journal. The purpose is to have a forum in which general doubts about the processes of publication in the journal, experiences and other issues derived from the publication of papers are resolved. For topics on particular articles, maintain the dialogue through the usual channels with your editor.

Developed by:



Powered by:



Follow us on @ScimagoJR

Scimago Lab, Copyright 2007-2020. Data Source: Scopus®

EST MODUS IN REBUS
Horatio (Satire 1,1,106)

Re: Your paper [HE_10307] submitted to International Journal of Hydrogen Energy

From: Shinfuku NOMURA (nomura.shinfuku.mg@ehime-u.ac.jp)

To: Ma.Brubaker@Elsevier.com

Date: Thursday, August 16, 2012, 01:01 PM GMT+8

Dear Marsha Brubaker

I already revised the highlights of our journal (HE_10307) and attached in this email.

Thank you

Prof. Nomura

>Dear Dr. Nomura,

>
>Please revise your Highlights so that each of the 3 to 5 bullet points summarizing core results of the paper do not exceed the , maximum 125 characters (every character, symbol, letter and space count as one) per bullet point. Thank you.

>
>Regards,
>Marsha Brubaker
>Journal Administrator
>Elsevier GJP

* Please note new e-mail address

** Prof. Shinfuku Nomura **
** **
** Department of Mechanical Engineering, Ehime University **
** 3 Bunkyo-cho Matsuyama Ehime 790-8577, Japan **
** **
** Email:nomura.shinfuku.mg@ehime-u.ac.jp **
** Phone:81(Japan)-89-927-9723 **
** Fax:81(Japan)-89-927-9744 **

 Highlights (rev.) of HE_10307.pdf
20.2kB

Available online at www.sciencedirect.com

SciVerse ScienceDirect

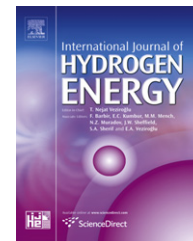
journal homepage: www.elsevier.com/locate/ije

Hydrogen production by radio frequency plasma stimulation in methane hydrate at atmospheric pressure

Andi Erwin Eka Putra ^{a,b}, Shinfuku Nomura ^{a,*}, Shinobu Mukasa ^a, Hiromichi Toyota ^a

^a Graduate School of Science and Engineering, Ehime University, Matsuyama 790-8577, Japan

^b Department of Mechanical Engineering, Hasanuddin University, Makassar 90245, Indonesia

ARTICLE INFO

Article history:

Received 22 May 2012

Received in revised form

19 July 2012

Accepted 21 July 2012

Available online 12 September 2012

Keywords:

Methane hydrate

Radio frequency plasma

Hydrogen

Plasma in-liquid

ABSTRACT

Methane hydrate, formed by injecting methane into 100 g of shaved ice at a pressure of 7 MPa and reactor temperature of 0 °C, was decomposed by applying 27.12 MHz radio frequency plasma in order to produce hydrogen. The process involved the stimulation of plasma in the methane hydrate with a variable input power at atmospheric pressure. It was observed that production of CH₄ is optimal at a slow rate of CH₄ release from the methane hydrate, as analyzed by in light of the steam methane reforming (SMR) and the methane cracking reaction (MCR) processes in accordance with the content of gas production. In comparison with the steam methane reforming (SMR), it was found that methane-cracking reaction (MCR) was dominant in conversion of CH₄ into hydrogen. An H₂ content of 55% in gas production was obtained from conversion of 40% of CH₄ at an input power of 150 W. The results clearly show that hydrogen can be directly produced from methane hydrate by the in-liquid plasma method.

Copyright © 2012, Hydrogen Energy Publications, LLC. Published by Elsevier Ltd. All rights reserved.

1. Introduction

Sustained economic growth coupled with environmental protection requires the availability of environmentally-friendly energy. Hydrogen, whose current application is largest in the chemical industry, has great potential as a non-polluting fuel gas for this purpose. At present, hydrogen as an energy source must be produced mainly from fossil fuels such as natural gas, coal, and fuel oil. Methane, with its significant C:H ratio and availability, is a preferred energy source for producing hydrogen. Hydrogen is most commonly produced from steam methane reforming (SMR) and in commercial application supplies from 80 to 85% of the world's demand for hydrogen [1]. The SMR process converts natural gas or methane with steam at high temperature and high pressure by endothermic reaction, however in the second step in the

process to efficiently produce hydrogen, a large quantity of CO₂ is produced as a byproduct of the exothermic reaction.

A great deal of research is being conducted to increase the quantity and purity of hydrogen production for fuel cell needs using the economic resources and processes. Plasma generation technology seems very suitable for application in the hydrogen industry because its high temperature of greater than 1000 K could accelerate the reaction rate and could produce hydrogen from methane [2–4]. Research into plasma decomposition of other energy sources such as iso-octane and gasoline [4], and coal [5] has also been conducted. On the other hand, the technology for generating plasma in liquid by radio frequency (RF) or microwave (MW) irradiation has been conducted in the chemical fields concerned with the direct decomposition of the liquid itself for diamond deposition [6] and synthesis of nanoparticles [7]. MW plasma irradiation

* Corresponding author.

E-mail address: nomura.shinfuku.mg@ehime-u.ac.jp (S. Nomura).

has been successfully applied to produce 70–80% of hydrogen at atmospheric pressure from waste oil, and n-dodecane [8,9], as well as 65% of hydrogen from cyclopentane hydrate (CP) [10].

Methane hydrate known to exist in a stable form in deep sea deposits and permafrost at a low temperature and high pressure has a huge potential as an untapped source of methane. A single cubic meter of methane hydrate may contain as much as 170 m³ of methane [11] which estimates to be about 21×10^{15} m³ at STP condition throughout the world [12]. Therefore, methane production from methane hydrate is being actively researched through methods of depressurization [13] or thermal stimulation [14,15]. However, though hydrogen production from methane hydrate may be possible [12], it has not been investigated in detail.

Since RF irradiation could easily be used to generate plasma in water at high pressure [16] and the energy consumption required to produce hydrogen, oxygen, and hydrogen peroxide from water at atmospheric pressure is 0.4% of 150 W of RF power supplied [17]. It can be said that, RF plasma could be generated at a lower power than the MW plasma in water. Therefore, it is feasible that RF irradiation may be used to decompose the methane hydrate found in hydrate fields as a foreseeable source of hydrogen production by plasma stimulation that has the added benefit of minimizing any effect on global warming through the release of methane and CO₂ gas byproducts into the atmosphere.

In addition, gas hydrates for storage and transportation of natural gas at atmospheric pressure with the temperature below the freezing point of water, which is formed on the floating production unit of natural gas, can save 24% of the capital cost compared to the LNG process [18,19]. These hydrates may also be decomposed to produce hydrogen by the in-liquid plasma method.

In this paper, the initial experimental results of 27.12 MHz RF plasma stimulation to decompose methane hydrate into hydrogen at atmospheric pressure are presented. This study is a first step toward the ultimate goal of producing hydrogen from hydrate fields through the application of the in-liquid plasma method. In-liquid plasma can be sustained in a bubble created at the tip of electrode by the evaporation of the liquid, and the cooling properties of the liquid itself can mitigate heat damage to the electrode. Furthermore, the in-liquid plasma method results a high localized temperature with the liquid temperature around the plasma tending to remain constant in its environmental state. With RF plasma in water, the electron temperature, and rotational temperature reach 3400 K at atmospheric pressure [17].

2. Methane hydrate formation

Hydrates are formed into crystalline solids by the presence of constituent molecules such as methane, CO₂, and even cyclopentane within the cavity of lattice water. For methane hydrate formation by exothermic reaction, the correspondence between the amount of water and methane, and a suitable combination of pressure and temperature needs to be considered. Methane hydrate categorized as cubic structure I (sI) has an ideal unit cell formula of $6(5^{12}6^2) \cdot 2(5^{12}) \cdot$

$46\text{H}_2\text{O}$. This means that the ideal composition of methane hydrate is CH₄·5.75H₂O assuming all cavities are occupied by methane. The pressure phase equilibrium at 0 °C is approximately 2.3 MPa with a mixed content of ice, liquid water and hydrate [20]. In addition, stirring can be effective to enhance the gas consumption rate through an increased gas–liquid interface [21], and injecting methane (290 K, 30 MPa) into granular ice can complete the reaction of methane hydrate formation in approximately 12–15 h [22]. Methane hydrate formation by cycling pressure and temperature close to the hydrate stability boundary at 4–5 MPa and at 273.16–279.16 K can convert approximately 90% of water to methane hydrate [23]. In addition, Stern et al. [22] investigated the dissociation rate of methane hydrate at atmospheric pressure and suggested that methane hydrate can be temporarily stored and transported at 242–271 K, at 0.1 MPa.

Methane hydrate formation has also been synthesized for this study by injecting pressurized methane into shaved ice in the formation reactor. Fig. 1 depicts the experimental equipment used for methane hydrate in this research. The volume of the reaction vessel is 400 mL with a height of 140 mm and an inner diameter of 60 mm. The maximum pressure is 15 MPa, and temperature of reactor casing is maintained by an ethylene glycol cooling medium. A magnetic stirrer with a diameter of 40 mm and a methane injection tube are positioned 30 mm from the reactor bottom.

100 g of shaved ice were put into the formation reactor that had been cleaned by water. The air in the reactor was then purged by decompression using an aspirator and substituted with methane. The temperature of the cooling bath was kept constant at 0 °C, the methane was pressurized to about 7 MPa and the stirrer was activated to agitate the solution at 400 rpm. The temperature of methane hydrate formation was monitored by a thermocouple at 30 mm from the reactor bottom. Temperature and pressure during the process was recorded every 15 min.

Methane hydrate began to be formed immediately after the stirrer was activated at the beginning of the process, which was characterized by the pressure drop to approximately 5.6 MPa and an increase in temperature to approximately 2 °C.

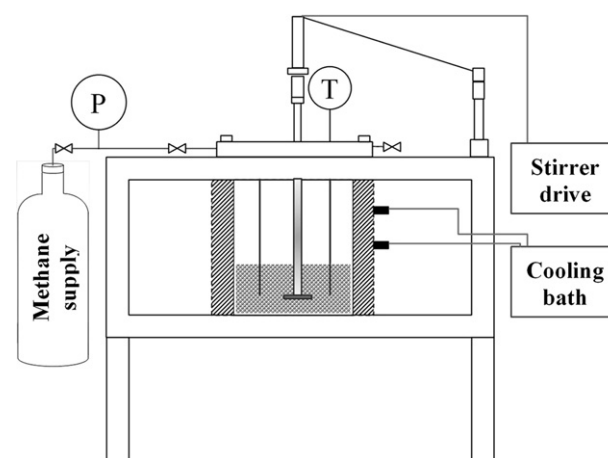

Fig. 1 – Structure of the methane hydrate formation apparatus.

This was due to an exothermic reaction, as shown in Fig. 2. The methane was pressurized to 7 MPa with a corresponding increase in temperature to approximately 6 °C. The formation of methane hydrate then occurred continuously from the melting ice. The remaining ice was melted to form hydrates by a change in the temperature of cooling bath to 2 °C after the stirrer was stopped. Pressurization with methane to 7 MPa was performed in several times. After the methane hydrate formation process was complete, when the formation pressure was constant at 7 MPa, it rapidly reduced to atmospheric pressure with the further cooling process by the refrigerator. The further cooling of the hydrate is required to prolong the completion of hydrate dissociation [24].

3. Hydrogen production procedure

The main parts of experimental apparatus for methane hydrate decomposition are shown in Fig. 3. Plasma generated at the tip of the electrode decomposed methane hydrates in the reactor vessel at atmospheric pressure.

A transparent silica glass pipe was used as the reactor vessel with an inner diameter of 55 mm, a thickness of 2 mm, and a height of 85 mm. An electrode consisting of 2 mm of a tungsten rod protruding from a silica glass tube with an outer diameter of 6 mm and a thickness of 1.5 mm as dielectric substance was inserted from the bottom of the reactor and connected to a 27.12 MHz RF power source (T161-5766LQ, Thamway) via a matching box (T020-5766M, Thamway). Additionally, a copper tube was inserted from the top of the reactor to a distance of 4 mm from the lower electrode that served not only as a counter electrode but also as gas outlet as well.

30 g of methane hydrate were poured into the reactor vessel. Then, an aspirator decompressed the reactor vessel to expel air and to facilitate plasma generation. The generation of RF plasma in methane hydrate was conducted at 150, 180, and 200 W at atmospheric pressure. The power values were calculated by subtraction of the reflected power from the forward power. The reflected power was kept constant at the lowest possible level. A gas chromatograph (Shimadzu 8A) with a column temperature 60 °C (6 min hold) to 160 °C and Helium as the carrier gas was used to identify the contents of collected gas.

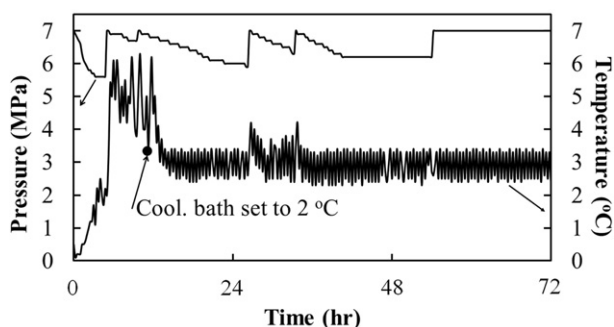

Fig. 2 – Pressure and temperature for methane hydrate formation.

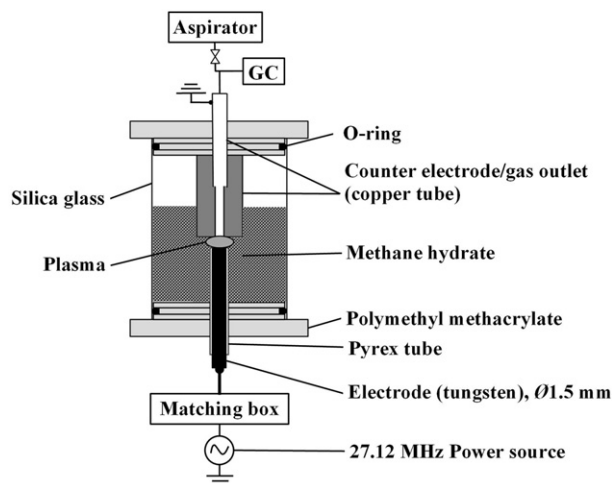
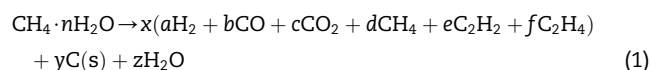

Fig. 3 – Experimental apparatus for RF plasma decomposition of methane hydrate.

4. Results and discussion

According to Stern et al. [22], it is possible to save 93% hydrates in storage condition at 242–271 K and 0.1 MPa. The dissociation rate of hydrates at 0.1 MPa increases with an increased storage temperature, but methane hydrate containing 30% CH₄, after having been exposed to further cooling to –8 °C, takes 12 days for the completion of hydrate dissociation at –4 °C and 0.1 MPa [24]. This stability provided the opportunity for methane hydrate to be decomposed by 27.12 MHz RF plasma at atmospheric pressure. The plasma generated by the in-liquid plasma method results a high temperature localized between the two electrodes, which then results in heating the deposit temperature above the temperature for hydrate dissociation. Methane (CH₄), which is released by the heating process, flows toward outlet pipe through the plasma. The plasma then decomposes methane (CH₄) into the product gases. The product gases are hydrogen (H₂), methane (CH₄), carbon monoxide (CO) as the main products, and byproducts, consisting of carbon dioxide (CO₂), acetylene (C₂H₂), ethylene (C₂H₄), and carbon (C) adhered to the reactor walls. The totality of the reactions can be expressed by the following:



Where, a, b, c, d, e, f are ratios of gas content,

$$x = 2/(a - b - 2c + 2d + e + 2f) \quad (2)$$

$$y = (a - 3b - 4c - 3e - 2f)/(a - b - 2c + 2d + e + 2f) \quad (3)$$

and

$$z = n - 2(b + 2c)/(a - b - 2c + 2d + e + 2f) \quad (4)$$

To identify the hydrate number and dissociation enthalpy that can be applied in the series of calculation refer to the previous study [25,26].

Based on the pressure conditions of 1.9–9.7 MPa and temperature of formation of 253–285 K, the methane hydrate had a stoichiometric number of $n = 5.81\text{--}6.10$ H₂O with an average CH₄·5.99(±0.07)H₂O [25]. In addition, the Clapeyron equation was used to determine the hydrate number and the dissociation enthalpy which were found to be 5.90 ± 0.3 and 53.5 ± 1.3 kJ/mol respectively [26]. This is in agreement with the hydrate number (n) of Handa, $n = 6.00(\pm 0.01)$. Therefore, it may be assumed that the amount of (CH₄) in methane hydrate is referred to by the hydrate number of Handa, $n = 6.00$ and dissociation enthalpy of MH is 53.5 kJ/mol [26].

The CH₄ conversion was influenced by the rate of methane hydrate dissociation which was assumed to be equivalent to the gas production rate. The gas production rate, which increases with increasing input power, is 0.018, 0.022, and 0.027 mol/min at 150, 180, and 200 W respectively. Therefore, the total CH₄ conversion ratio was calculated using Eq. (5):

The total of CH₄ conversion ratio

$$= \left[\frac{((\text{CH}_4)_{\text{reactant}} - (\text{CH}_4)_{\text{product}})}{(\text{CH}_4)_{\text{reactant}}} \right] \times 100 \quad (5)$$

(CH₄)_{reactant} was determined by the mole of CH₄ trapped in 30 g of methane hydrate, and (CH₄)_{product} was the mole of CH₄ content in the product gases. Referring to the hydrate number (n) = 6.00, the amount of CH₄ trapped in 30 g of methane hydrate is expected to be 0.242 mol. The actual CH₄ content in the product gases was 0.146 mol at 150 W, which then remained constant in the range 0.161–0.165 mol with increase of the input power, as shown in Fig. 4. Then, the total CH₄

conversion ratio as calculated by Eq. (5) was found to have increased from 32 to 40% with a decrease of input power. The increased CH₄ conversion ratio was followed by an increase in the H₂ content in product gases from 48% to 55%. Therefore, a slow rate of CH₄ release from the methane hydrate can optimize plasma decomposition of CH₄ to produce hydrogen.

The chemical reaction of plasma decomposition of CH₄ that is demonstrated in Eq. (1) is based on methane hydrate dissociation (MHD), steam methane reforming (SMR) and methane-cracking (MCR) reactions. In the initial MHD reaction as described above CH₄ and water are produced. Then, the SMR and the MCR reactions simultaneously decompose the released CH₄ into H₂, CO, and other byproducts. The amount of water that turns into steam by the plasma reacted with the CH₄ to produce H₂, CO and CO₂ through the SMR process. Similarly, a certain amount of CH₄ was directly decomposed by the plasma by MCR to produce H₂ and the byproducts of C₂H₂, C₂H₄, and C(s). The reaction equations and enthalpies concerned with MHD, SMR, and MCR are shown in Table 1.

Taking into account of the amount of CO and CO₂ content in the gas production, the CH₄ conversion ratio by the SMR was calculated as shown in Eq. (6). The CH₄ conversion ratio by MCR in Eq. (7) was calculated from the amount of C₂H₂ and C₂H₄ content in product gases and carbon production.

The CH₄ conversion ratio by SMR

$$= \left[\frac{(\text{CH}_4)_{\text{consumed by SMR}}}{(\text{CH}_4)_{\text{reactant}}} \right] \times 100 \quad (6)$$

The CH₄ conversion ratio by MCR

$$= \left[\frac{(\text{CH}_4)_{\text{consumed by MCR}}}{(\text{CH}_4)_{\text{reactant}}} \right] \times 100 \quad (7)$$

The CH₄ conversion ratio by SMR is proportional to the amount of available steam. Unfortunately, the steam produced in this process was estimated to be only about 1% of the water content in the methane hydrate. Meanwhile, in comparison with SMR, MCR was found to be dominant in the CH₄ conversion, with a ratio that reached to 27–31% as shown in Fig. 5.

H₂ selectivity is determined by the number of H atoms in H₂ content of the product gases, divided by the total of H atoms in the converted reactant. Similarly, CO selectivity is defined as the number of C atoms in CO contents of the product gases, divided by the total of C atoms in the converted reactant. Likewise, H₂ yield is the number of H atoms in H₂ content of the product gases, divided by the total of H atoms in the reactant. Fig. 6 shows that the H₂ selectivity tends remain constant around 97% with a change in the input power and the

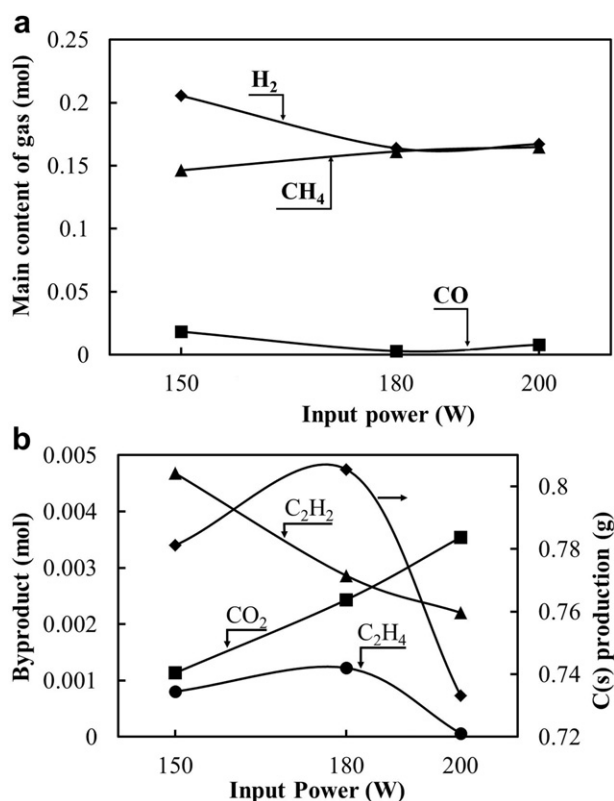

Fig. 4 – Content of product gases from methane hydrate decomposition.

Table 1 – Basic reactions for methane hydrate decomposition.

Reactions	ΔH (kJ/mol)	Category
CH ₄ ·nH ₂ O → CH ₄ (g) + nH ₂ O	53.5 ± 1.3 [21]	MHD
CH ₄ + H ₂ O → 3H ₂ + CO	206.16	SMR
CO + H ₂ O → H ₂ + CO ₂	-41.2	SMR
CH ₄ → 2H ₂ + C (s)	74.87	MCR
2CH ₄ → 3H ₂ + C ₂ H ₂	376.47	MCR
2CH ₄ → 2H ₂ + C ₂ H ₄	202.21	MCR

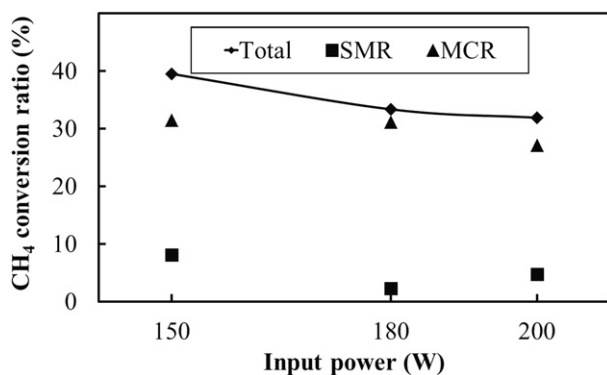

Fig. 5 – Effect of input power on CH₄ conversion ratio.

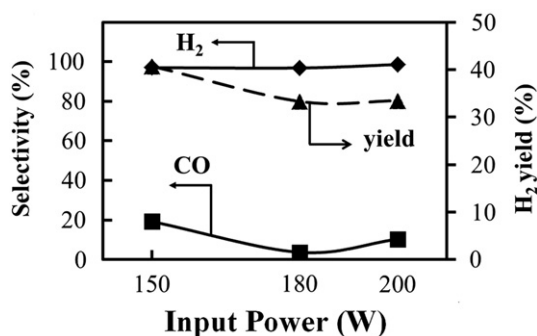

Fig. 6 – Main product selectivity and H₂ yield for methane hydrate decomposition.

CO selectivity was at a maximum of 19% at 150 W. In addition, the maximum H₂ yield of 41% resulted at 150 W.

The amount of energy used to decompose 1 mol of methane hydrate to produce hydrogen with RF plasma, is shown in Fig. 7. Consequently, the power consumed when taking the gas production rate into account was estimated to be approximately 6.3–7.3% of the input power.

In addition, as mentioned above, the C(s) generated by the MCR as a byproduct in this process is estimated by the balance of the reaction as shown in Fig. 4b. In a real hydrate system in a porous medium, C(s) attached to the reactor wall in this study may also attach to the surface of the porous medium.

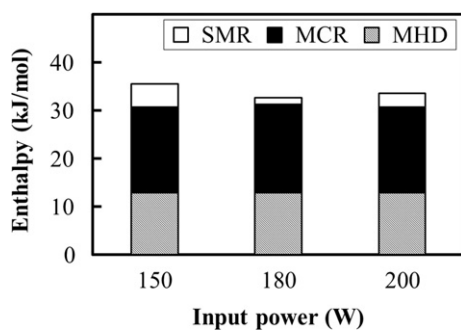

Fig. 7 – Net amount of energy used for methane hydrate decomposition.

The deposition of C(s) on the porous medium could significantly reduce its permeability and also allow the blockage of the porous medium to interfere with hydrogen production. On the other hand, the availability of water in a real hydrate system could be expected to meet the needs for steam to optimize the SMR in the evaporation process of plasma and C(s) production by the MCR would decrease. Both of these issues are not clear and will need to be examined extensively in experimental studies in the future.

5. Conclusion

27.12 MHz RF plasma decomposition of methane hydrate was proposed as a method for production of hydrogen with variations in input power at atmospheric pressure. In this investigation, steam methane reforming and methane cracking reactions simultaneously occurred to decompose CH₄ released from methane hydrate, with the optimal process being found at 150 W, due to the slow rate of methane release. The result at 150 W is a CH₄ conversion rate of 40%; an H₂ yield of 41% and an H₂ selectivity of 97% at an H₂ content in product gases of 55%; based on the enthalpy of formation for 1 mol of gas of 35.6 kJ/mol with a power consumption of about 10 W.

REFERENCES

- [1] Boyano A, Blanco-Marigorta AM, Morosuk T, Tsatsaronis G. Exergoenvironmental analysis of a steam methane reforming process for hydrogen production. *Energy* 2011;36: 2202–14.
- [2] Jasi'nski M, Dors M, Mizeraczyk J. Application of atmospheric pressure microwave plasma source for production of hydrogen via methane reforming. *Eur Phys J D* 2009;54: 179–83.
- [3] Yang YC, Lee BJ, Chun YN. Characteristics of methane reforming using gliding arc reactor. *Energy* 2009;34:172–7.
- [4] Kim TS, Song S, Chun KM, Lee SH. An experimental study of syn-gas production via microwave plasma reforming of methane, iso-octane and gasoline. *Energy* 2009;xxx:1–10.
- [5] Galvita V, Messerle VE, Ustimenko AB. Hydrogen production by coal plasma gasification for fuel cell technology. *Int J Hydrogen Energy* 2007;32:3899–906.
- [6] Toyota H, Nomura S, Takahashi Y, Mukasa S. Submerged synthesis of diamond in liquid alcohol plasma. *Diamond Relat Mater* 2008;17:1902–4.
- [7] Hattori Y, Mukasa S, Toyota H, Inoue T, Nomura S. Synthesis of zinc and zinc oxide nanoparticles from zinc electrode using plasma in liquid. *Mater Lett* 2011;65:188–90.
- [8] Nomura S, Toyota H, Tawara M, Yamashita H, Matsumoto K. Fuel gas production by microwave plasma in liquid. *Appl Phys Lett* 2006;88(23). 231502-1-3.
- [9] Nomura S, Toyota H, Mukasa S, Yamashita H, Maehara T, Kawashima A. Production of hydrogen in a conventional microwave oven. *J Appl Phys* 2009;106. 073306-1-4.
- [10] Nomura S, Putra AEE, Mukasa S, Yamashita H, Toyota H. Plasma decomposition of clathrate hydrates by 2.45 GHz microwave irradiation at atmospheric pressure. *Appl Phys Express* 2011;4. 066201-1-3.
- [11] Kim NJ, Lee JH, Cho YS, Cun W. Formation enhancement of methane hydrate for natural gas transport. *Energy* 2010;35: 2717–22.

- [12] Rice W. Hydrogen production from methane hydrate with sequestering of carbon dioxide. *Int J Hydrogen Energy* 2006; 31:1955–63.
- [13] Ahmadi G, Ji C, Smith DH. Production of natural gas from methane hydrate by a constant downhole pressure well. *Energy Convers Manage* 2007;48:2053–68.
- [14] Castaldi MJ, Zhou Y, Yegulalp TM. Down-hole combustion method for gas production from methane hydrates. *J Pet Sci Eng* 2007;56:176–85.
- [15] Tsimpanogiannis IN, Lichtner PC. Parametric study of methane hydrate dissociation in oceanic sediments driven by thermal stimulation. *J Pet Sci Eng* 2007;56:165–75.
- [16] Nomura S, Mukasa S, Toyota H, Miyake H, Yamashita H, Maehara T, et al. Characteristics of in-liquid plasma in water under higher pressure than atmospheric pressure. *Plasma Sources Sci Technol* 2011;20:034012–9.
- [17] Mukasa S, Nomura S, Toyota H, Maehara T, Yamashita H. Internal conditions of a bubble containing radio-frequency plasma in water. *Plasma Sources Sci Technol* 2011;20: 034020–8.
- [18] Gudmundsson JS, Andersson V, Levik OI. Gas storage and transport using hydrates. Offshore mediterranean conference, Ravenna, 1997, March 19–21.
- [19] Gudmundsson JS, Børrehaug A. Frozen hydrate for transport of natural gas. 2nd International conference on natural gas hydrate, Toulouse, France, 1996, June 2–6.
- [20] Sloan DE, Koh CA. *Clathrate hydrates of natural gases*. 3th ed. Boca Raton, FL: CRC Press, Taylor & Francis Group; 2008.
- [21] Mork M, Gudmundsson JS. Hydrate formation rate in a continuous stirred tank reactor. International gas research conference, Amsterdam, 2001, November 5–8.
- [22] Stern LA, Circone S, Kirby SH, Durham WB. Anomalous preservation of pure methane hydrate at 1 atm. *J Phys Chem B* 2001;105:1756–62.
- [23] Giavarini C, Maccioni F. Production of concentrated methane hydrates in bulk, at medium pressure. *J Chem Eng Data* 2008; 53:2282–7.
- [24] Giavarini C, Maccioni F. Self-preservation at low pressures of methane hydrates with various gas contents. *Ind Eng Chem Res* 2004;43:6616–21.
- [25] Circone S, Kirby SH, Stern LA. Direct measurement of methane hydrate composition along the hydrate equilibrium boundary. *J Phys Chem B* 2005;109:9468–75.
- [26] Anderson GK. Enthalpy of dissociation and hydrate number of methane hydrate from the Clapeyron equation. *J Chem Thermodyn* 2004;36:1119–27.